

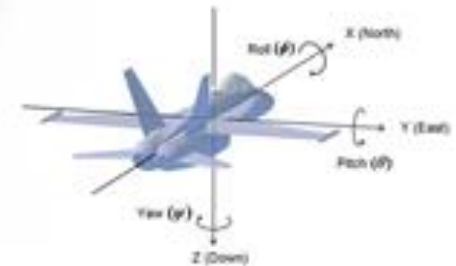

Driven by  
**CAN**  
*Aerospace*

ROS



## AdaPilot-EDU

Ada & SPARK Education and Research Ecosystem for  
Robotic and Drone Applications

## AdaPilot-EDU – Ada-SPARK & Robotics

AdaPilot-EDU is primarily intended for the **educational and research community**, and will be supported on the forum by experts from academia and industry who believe that using Ada and SPARK in education and research is fundamental **to forming the software engineers of tomorrow**. Ada and SPARK embody the best contemporary ideas in software technology, and students exposed to these languages at an early stage of their career become more skilled and principled programmers.

AdaPilot-EDU will focus on the **technical advantages** of these programming languages, the tools and support available for academics, as well provide an insight into their academic and industrial use through the **AdaRacer Flight Control System** project.

**Why Ada?** Ada is a state-of-the-art programming language with a set of **unique technical features** that make it highly effective for use in large, complex and safety-critical projects. Its approach of detecting errors as soon as possible makes it especially suitable for robotic applications, where **safety, security, and reliability are critical**. **SPARK** is a formally-defined programming language based on Ada, intended to be secure and to support the development of **high-integrity software**.

<http://www.adacore.com/adaanswers/benefits-and-features>

# AdaPilot-EDU Introduction

AdaPilot-EDU is an open-source autopilot project based on the Ada & SPARK programming language and ARM Cortex-M MCU.

The autopilot, also known as the „Digital Flight Control System“, is subdivided into two main bricks allowing high modularity and flexibility:

- **Flight Control System (FCS)**
- **Mission Management Computer (MMC)**

To reduce costs and complexity, the AdaPilot-EDU FCS combines the **Flight Control Computer** and **AHRS** functions on a single board to be handled by a single MCU.

External application specific sensors are handled and integrated using an external **Mission Computer** (Companion Computer) running ROS (Robot Operating System) and connected through the CANaerospace avionics data bus protocol.

**CANaerospace** is an extremely lightweight protocol/data format definition which was designed for the highly reliable communication of microcomputer-based systems in airborne applications via Controller Area Network (CAN).

## AdaPilot-EDU Core Technologies

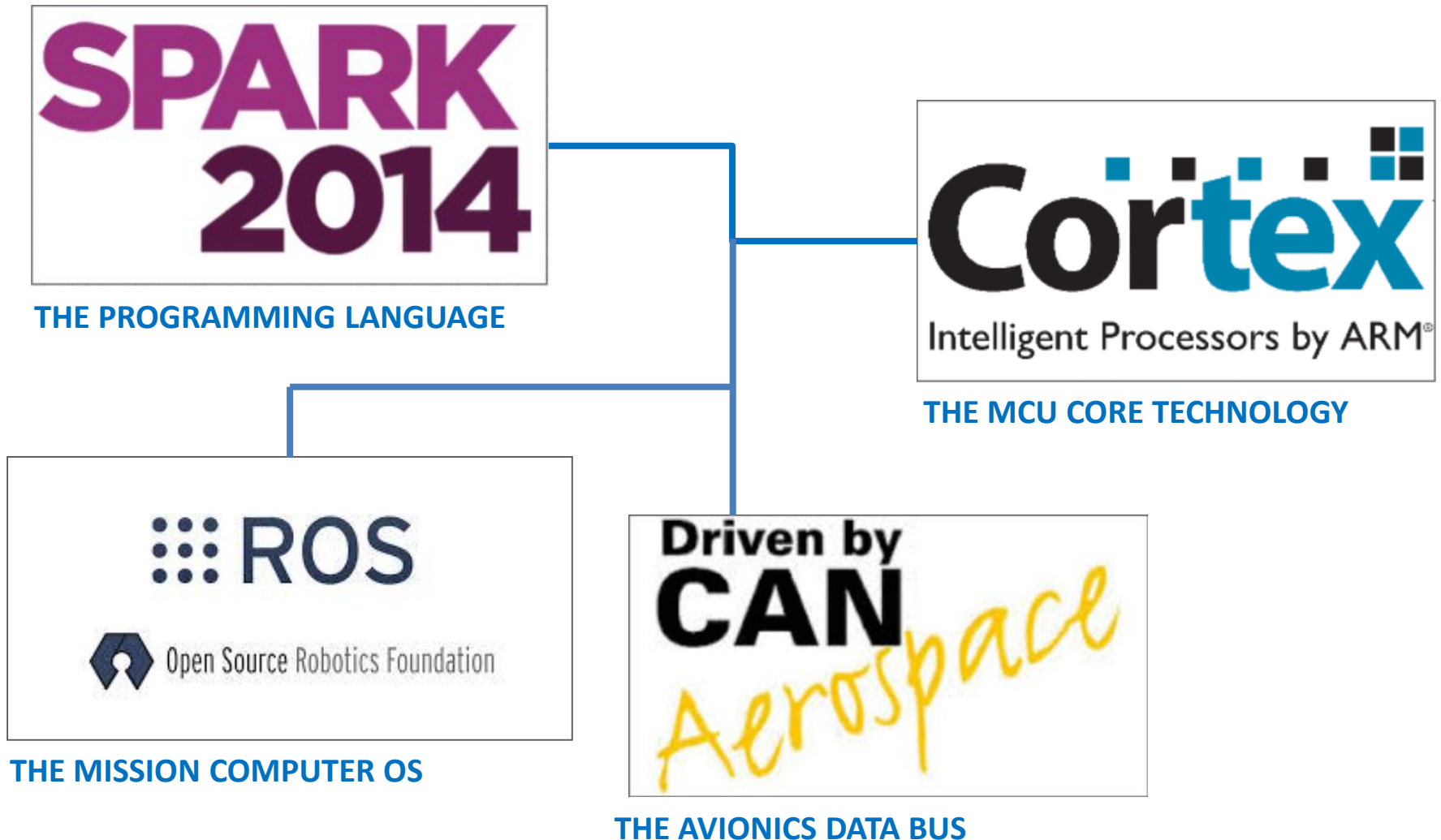

## AdaPilot-EDU Function Block Diagram

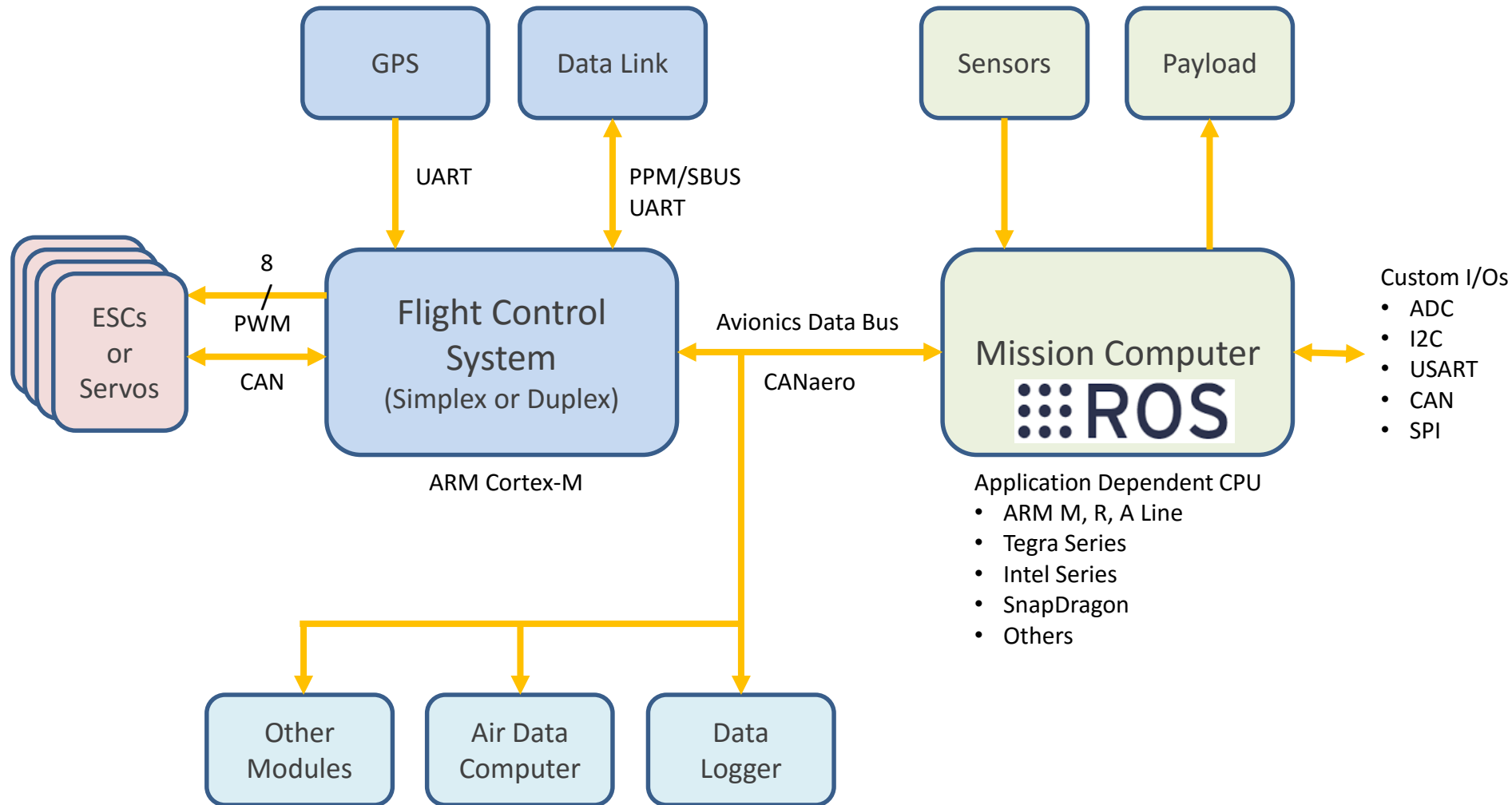

## AdaPilot-EDU – StarterKit Boards

AdaPilot-EDU StarterKit Boards are compact development boards based on the **Modular Expansion Socket – MES**. They are the quickest way to prototype and build standalone robotic applications with MES boards, AdaPilot-EDU’s ever-expanding range of add-on boards. The core system is the **Modular Motherboard** available to carry up to 4 half size modules. For demanding computer vision applications, a NVIDIA Jetson TX1 carrier board is also available.

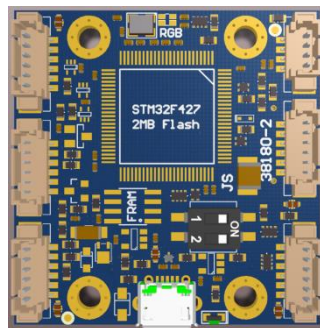

AdaRacer FCS

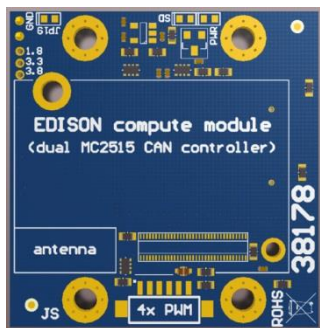

Mission Controller

Expansion Socket

Expansion Socket

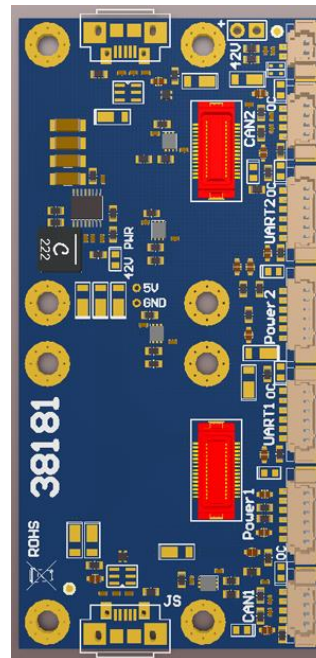

Modular Motherboard

Expansion Port

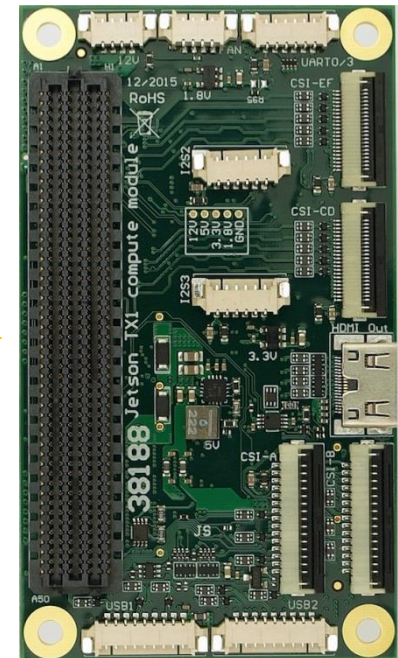

NVIDIA TX1 Carrier Board

## Mission Controller – Function Block Diagram

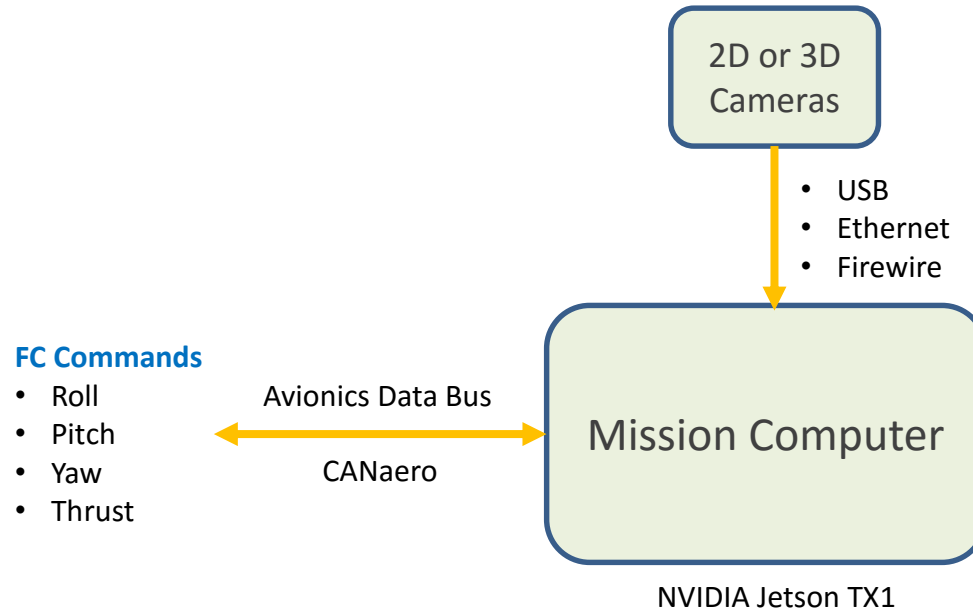

# Mission Controller – Overview

## NVIDIA Jetson TX1

The world's first supercomputer on a module, Jetson TX1 is capable of delivering the performance and power efficiency needed for the la. It's built around the revolutionary NVIDIA Maxwell™ architecture with 256 CUDA cores delivering over 1 TeraFLOPs of performance.

## OpenCV4Tegra

A free library provided by NVIDIA containing optimizations for NVIDIA's Tegra CPUs (ARM NEON SIMD optimizations, multi-core CPU optimizations and some GLSL GPU optimizations).

## ROS (Robot Operating System)

ROS (Robot Operating System) provides libraries and tools to help software developers create robot applications. It provides hardware abstraction, device drivers, libraries, visualizers, message-passing, package management, and more. ROS is licensed under an open source, BSD license.



## AdaPilot-EDU MAVLink Support

To speed up development processes, AdaPilot-EDU supports MAVLink, a protocol for communicating with small unmanned vehicles. It is designed as a header-only message marshaling library. MAVLink was first released early 2009 by Lorenz Meier under LGPL license. Current ground control software supporting MAVLink and supported by the AdaPilot-EDU program are: QgroundControl and APM Planner.



# AdaRacer FCS

## Education and Research Flight Control System

# FCS Overview & Description

## AdaRacer Flight Control System

It measures and evaluates a multitude of sensory parameters, the aircraft's environment as well as operational limitations. It handles auto-trim adjustments, the stability augmentation, vehicle-tailored flight control law algorithms, motor control (PWM/CAN) generation, data logging (black box) and basic autopilot functions.

## Firmware: FlightOS-M4

The embedded firmware is named "FlightOS-M4" and is the official AdaRacer firmware. The designation "M4" indicates this firmware is targeting the ARM Cortex-M4 MCU platform. Two firmware branches will be available:

- **Stable: Release Candidate for free user community usage**
- **Experimental: For experimental purposes only, unstable**

The FlightOS-M4 will be entirely programmed in Ada 2012 and SPARK 2014 languages. A CLI (Command Line Interface) through a RS232 is available for configuration, service and maintenance activities.

## AdaRacer FCS – Flexible & Rugged

AdaRacer FCS is part of the [AdaPilot-EDU Ecosystem](#), the educational environment about Ada and SPARK programming for Education and Research in Robotic Applications, and based on the ARM Cortex-M4 architecture.

The AdaRacer FCS hardware was designed to be [100% PX4 software compatible](#) to allow a smooth transition of PX4 code developer to the AdaPilot Ecosystem running both PX4 firmware code and AdaPilot code on the same reference hardware platform. This [helps dramatically the correct and quick understanding](#) of the Ada and SPARK programming language in relation to a flight control system project.

Although the AdaRacer FCS was not designed with safety criticality in mind, [particular attention](#) was made in the hardware design process covering ESD, and noise filtering aspects.

AdaRacer FCS is also the perfect companion for [in-flight testing of new SPI and I2C MEMS Sensors](#), offering a onboard 9-axis reference IMU and barometric sensor, and an external SPI extension port.

# FlightOS-M4 Overview

The FlightOS-M4 will be responsible for the following tasks:

- Stability Augmentation System (on-board IMU)
- Basic Autopilot Functions
- Fail-Safe Functions
- Actuator Mixer Matrix and Control (PWM or CAN)
- Reading Pilot Control Inputs (PPM/SBUS or CANaerospace)
- Generation of Telemetry Data and Alerts (UART or CANaerospace)
- Data Logging (Black Box)

## AdaRacer FCS – Hardware Block Diagram

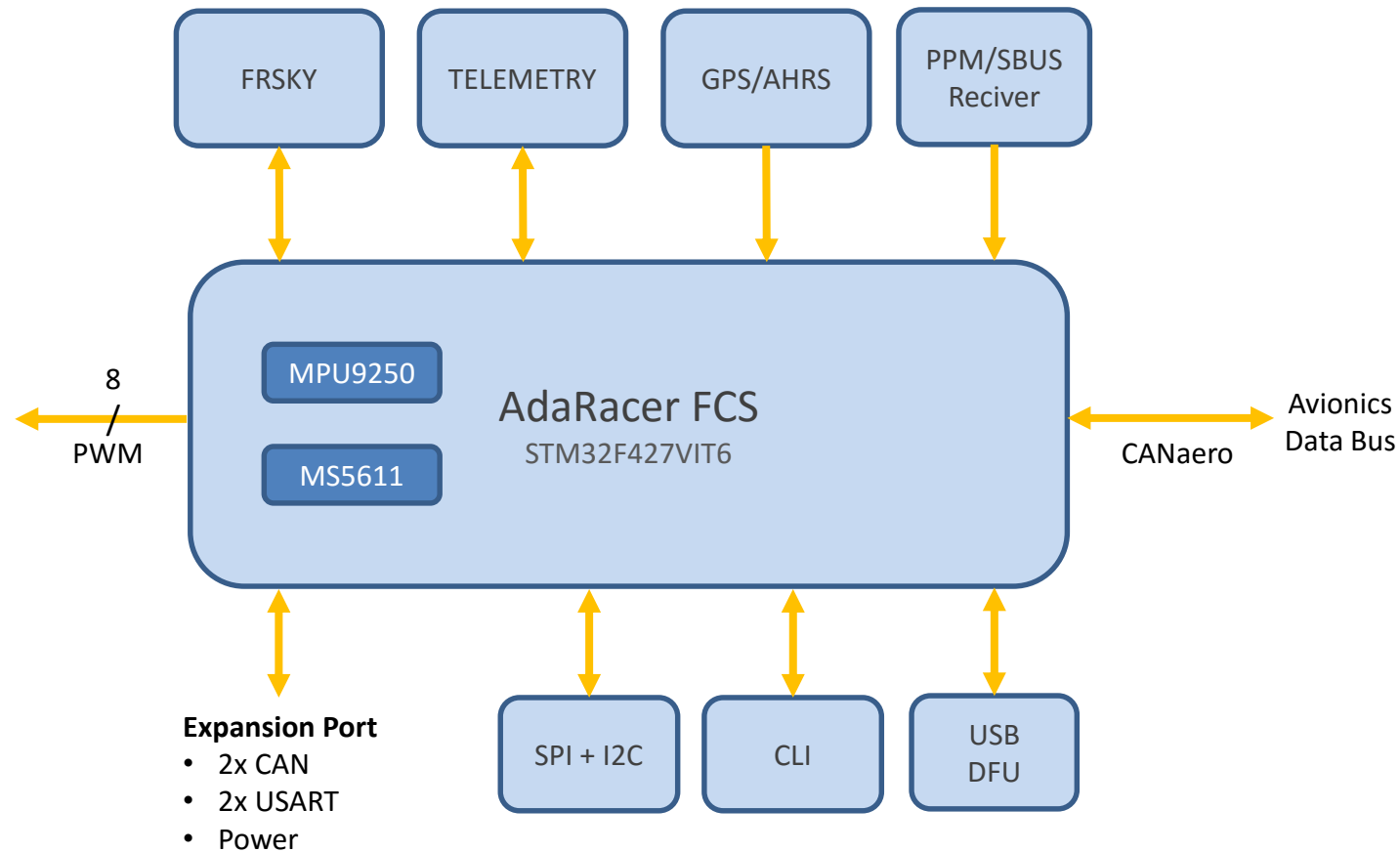

# AdaRacer FCS – I/O Overview

## MCU:

- STM32F427

## MEMS Sensor:

- MPU9250 (9-axis IMU)
- MS5611 (baro pressure)

## Communication:

- 5x USART
- 1x ESP8266 (WiFi)
- 2x CAN
- 1x PPM/SBUS
- 1x FrSky

## Storage:

- 1x MicroSD Card
- 1x FRAM

## ESC Control

- 8x PWM

## Additional I/Os

- Modular Expansion Socket
- USB
- SPI
- I2C

**NOTE: All UART and PWM interfaces feature buffer/driver components for ESD protection and higher noise immunity level suppression to increase reliability.**

## AdaRacer FCS – PCB Overview

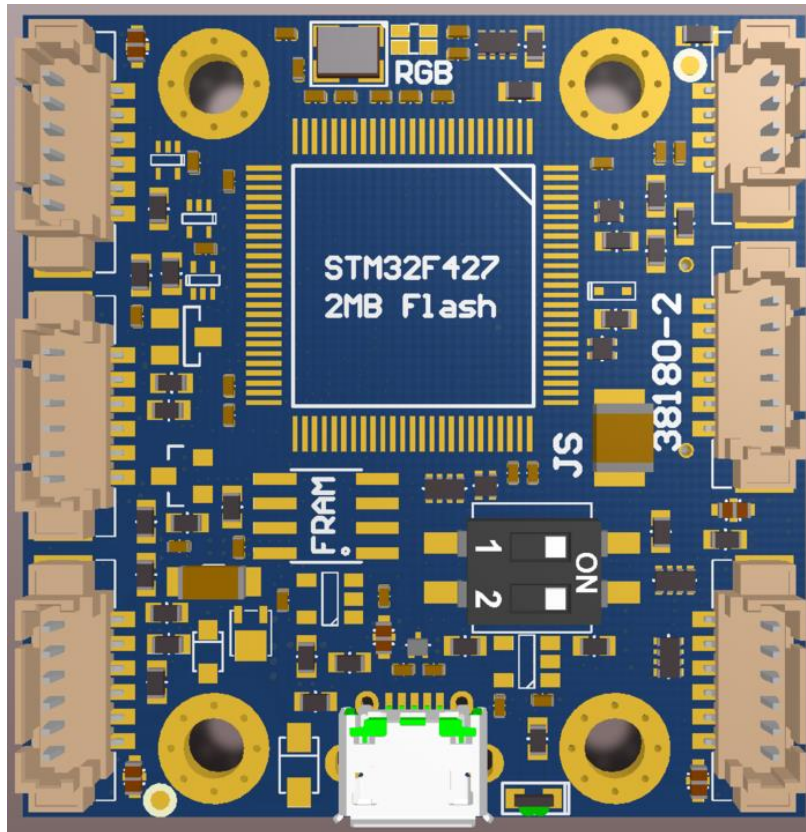

AdaRacer FCS – Top View

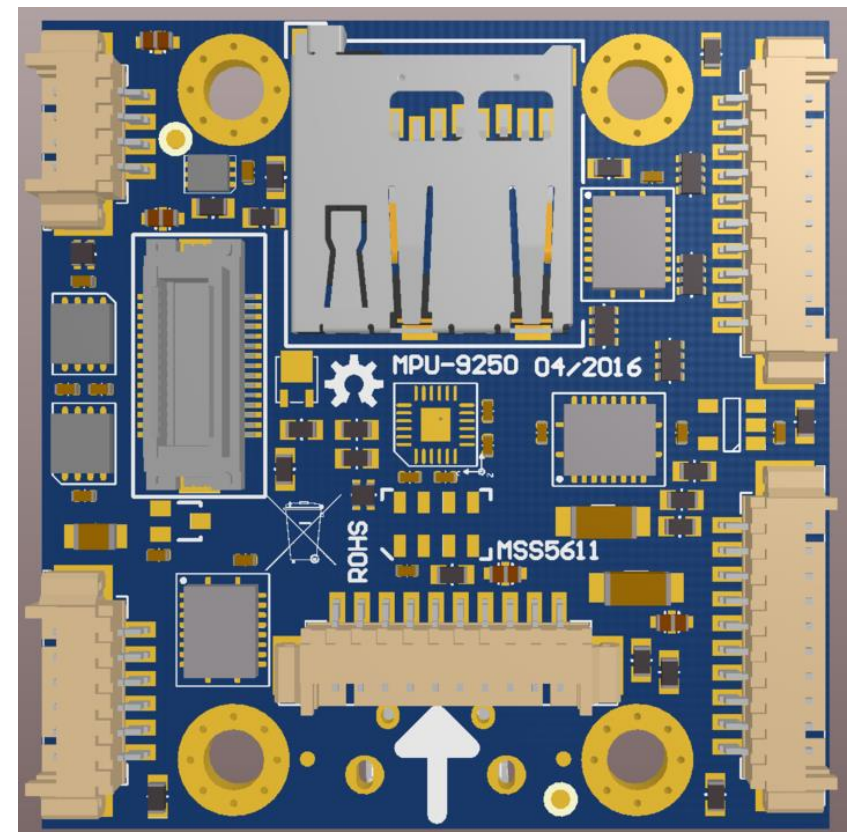

AdaRacer FCS – Bottom View



## AdaRacer FCS – PCB Overview

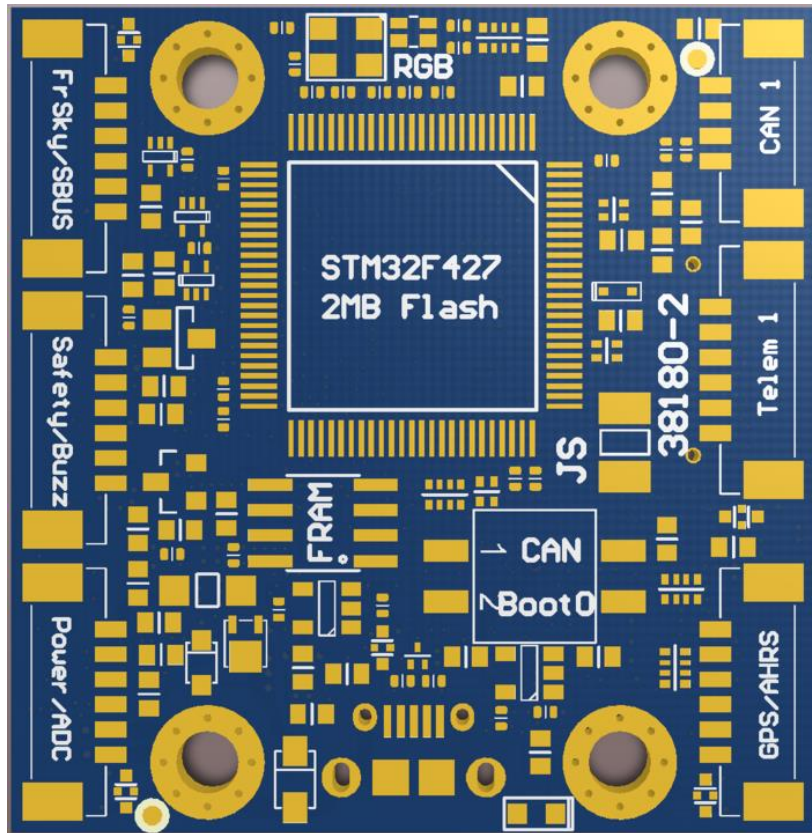

AdaRacer FCS – Top View

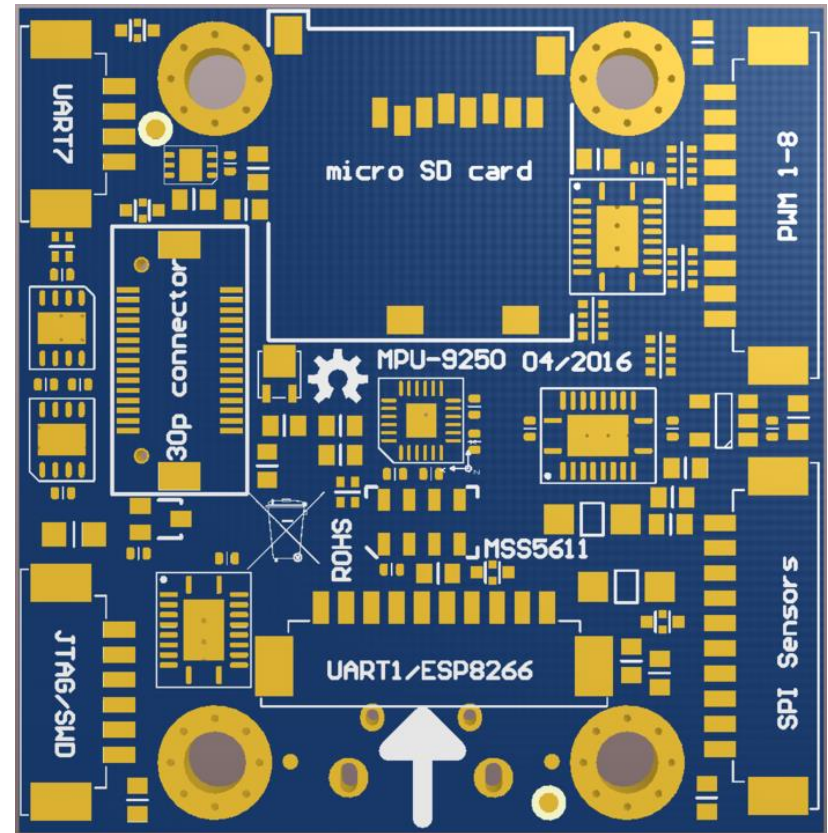

AdaRacer FCS – Bottom View

## AdaRacer Development Tools

AdaRacer is developed by a community of volunteers with the objective of creating a new global group of developers, users and enthusiasts around the Ada, SPARK, ARM, Linux and Mac OS environment. To allow a global interaction between all community members, AdaPilot-EDU offers the following open source development tools:



Forum / Blog / Guide / News



Issue & Project Tracking



Code Git Repository



Code Reviews



Real-Time Chat



Ada and SPARK GPL Editions

## AdaPilot-EDU Supporter



# AdaPilot Initiative Project Link

[adapilot.likeabird.eu](http://adapilot.likeabird.eu)

For questions please contact us:  
[info.adapilot@likeabird-group.eu](mailto:info.adapilot@likeabird-group.eu)